

ROLLERS



ENDLESS POSSIBILITIES

Our OT, NT, T Series rollers can withstand high static loading over long periods of time, often carrying the full load weight for more than a year with no adverse effects. Because loads are spread over a wide area and carried by the load plate and the contact rolls, rollers are ideal for many applications requiring the frequent movement of heavy loads.

OT, NT, T



OT, NT, T Rollers are fabricated from high strength steel. Load plates of 37.5-ton and higher capacities undergo a special machine process to minimize side-to-side movement of chain. The rollers can also be used inverted, as static conveyors.

ERF

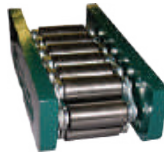

ERF Roller have no top plate and are often used where a trunnion mount is required, where an existing "foot pad" will become the roller's top plate, or where the load has a built-in cavity mount. Used upside down, the ERF Rollers become a heavy-duty conveyor allowing the load to slide with extremely low friction.

SHD



Super Heavy Duty Rollers are the highest capacity rollers that Hilman offers as standard models. 150 & 200 Ton frames come in Long (L) or Wide (W). Wide frame versions are offered with one complete (wide) chain or with two individual chains with a center plate (C) dividing them.

LOW COEFFICIENT OF FRICTION

The combination of a hard steel load plate and the chain of concentrically ground and hardened steel rolls offer the ultimate in low friction under the proper conditions. Ideal conditions would be an evenly centered load on the rollers with a hardened steel rolling surface that is smooth, level and clear of debris. In such instances, our rollers have been tested and are between 1 and 2% coefficient of friction.



SUPERIOR WEIGHT DISTRIBUTION

This roller design creates an even load bearing area or footprint. The wide footprint spans gaps in running plates and small cracks in a floor surface, allowing for an uninterrupted move. Due to the multi-rolled concept, if a roll should break, the load won't fall because there are other contact rolls on the chain to compensate.

ADVANTAGES

These rollers come in a variety of capacities, frame and top styles. They can easily be modified for any application.

OT OVERSIZED TOP
Overhang side to side

T FLUSH TOP
Add extra strength to the frame and offer a variety of mounting capabilities

NT NARROW TOP
Overhang front to back

ERF NO TOP PLATE
Lower height and lighter weight

TOP STYLES

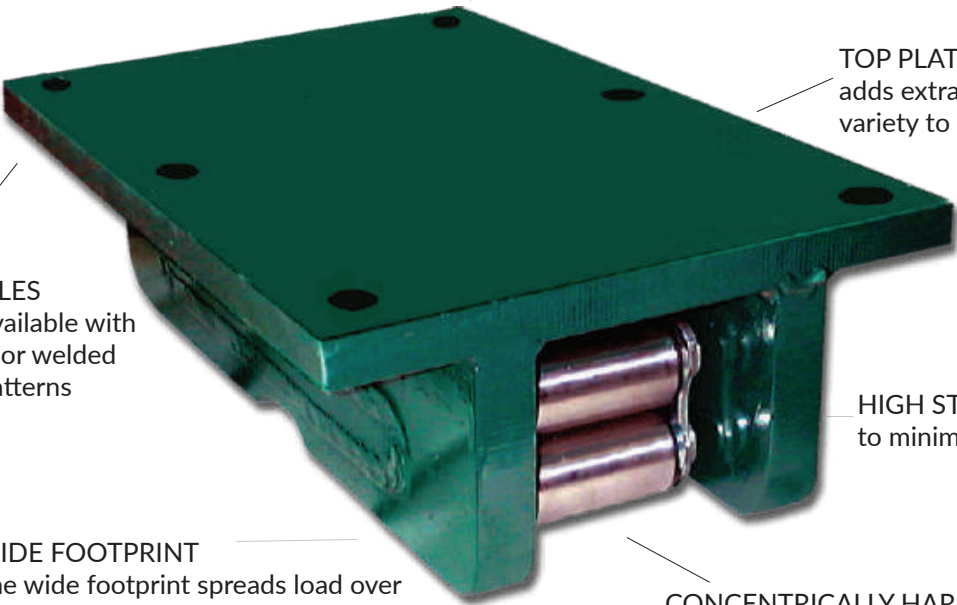

TOP PLATE
adds extra strength to the frame and variety to mounting capabilities

MOUNTING HOLES
OT and NT are available with standard bolt-on or welded mounting hole patterns

HIGH STRENGTH STEEL FRAME
to minimize side-to-side movement

WIDE FOOTPRINT
The wide footprint spreads load over greater area

CONCENTRICALLY HARDENED STEEL ROLLS
offer the ultimate in low friction under the proper conditions

EASILY MODIFIED

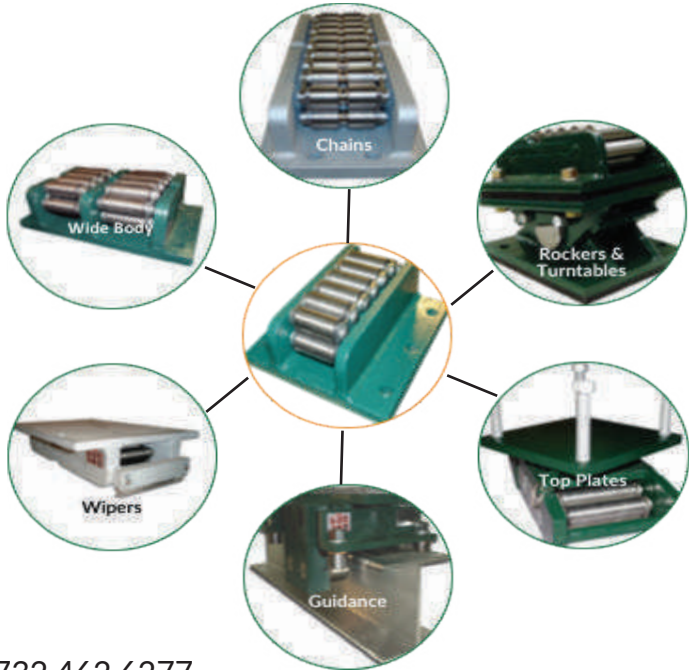

OT, NT, T, ERF

The OT, NT, T Rollers are fabricated from high strength steel. Load plates of 37.5-ton and higher capacities undergo a special machine process to minimize side-to-side movement of chain. The rollers can also be used inverted, as static conveyors.

OT

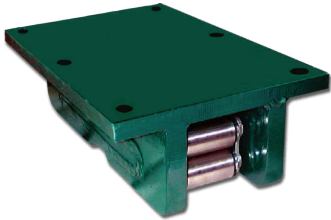

Capacity Metric Tons	<<<<<Body Dimensions>>>>>			<<<<<Top Plate Dimensions>>>>>			<<<<<Footprint>>>>>				
	Length	Height	Width	Thickness	Width	Length	Contact Rolls	Roll Dia. <<<<<Inches (mm)>>>>>	Roll Width <<<<<Inches (mm)>>>>>	Weight Lbs.(kgs)	
.75-OT	.75-ton	6.5 (165)	3.125 (79)	3.625 (92)	.375 (10)	7.0 (178)	6.5 (165)	6	11/16 (17)	2 (51)	13 (6)
1-OT	1-ton	6.0 (152)	2.375 (60)	3.5625 (91)	.375 (10)	6.0 (152)	6.0 (152)	6	11/16 (17)	2 (51)	11 (5)
2.5-OT	2.5-tons	6.5 (165)	3.625 (92)	4.125 (105)	.375 (10)	7.0 (178)	6.5 (165)	4	15/16 (24)	2-7/16 (62)	19 (9)
5-OT	5-tons	8.0 (203)	3.125 (79)	4.4375 (113)	.375 (10)	8.0 (203)	8.0 (203)	5	15/16 (24)	2-7/16 (62)	22 (10)
8-OT	8-tons	8.0 (203)	3.125 (79)	5.3125 (135)	.375 (10)	8.0 (203)	8.0 (203)	5	15/16 (24)	3-5/16 (84)	24 (11)
15-OT	15-tons	10.625 (270)	3.875 (98)	5.1875 (132)	.625 (16)	10.0 (254)	10.625 (270)	5	1-3/16 (30)	2-3/4 (70)	47 (21)
20-OT	20-tons	10.625 (270)	3.875 (98)	6.4375 (164)	.625 (16)	10.0 (254)	10.625 (270)	5	1-3/16 (30)	4 (102)	54 (24)
37.5-OT	37.5-tons	15.0 (381)	5.5 (140)	7.25 (184)	.75 (19)	12.0 (305)	15.0 (381)	6	1-5/8 (41)	3-1/2 (89)	119 (54)
50-OT	50-tons	18.5 (470)	5.5 (140)	7.25 (184)	.75 (19)	12.0 (305)	18.5 (470)	8	1-5/8 (41)	3-1/2 (89)	153 (69)
75-OT	75-tons	21.0 (533)	6.75 (171)	7.375 (187)	1.00 (25)	14.0 (356)	21.0 (533)	7	1-15/16 (49)	3-5/8 (92)	235 (107)

* Height includes Top Plate Thickness

NT



Capacity Metric Tons	<<<<<Body Dimensions>>>>>			<<<<<Top Plate Dimensions>>>>>			<<<<<Footprint>>>>>				
	Length	Height	Width	Thickness	Width	Length	Contact Rolls	Roll Dia. <<<<<Inches (mm)>>>>>	Roll Width <<<<<Inches (mm)>>>>>	Weight Lbs.(kgs)	
.75-NT	.75-ton	6.5 (165)	3.125 (79)	3.625 (92)	.375 (10)	3.5 (89)	8.0 (203)	6	11/16 (17)	2 (51)	11 (5)
1-NT	1-ton	6.0 (152)	2.375 (60)	3.5625 (91)	.375 (10)	3.5 (89)	8.0 (203)	6	11/16 (17)	2 (51)	10 (5)
2.5-NT	2.5-tons	6.5 (165)	3.625 (92)	4.125 (105)	.375 (10)	4.0 (102)	9.5 (241)	4	15/16 (24)	2-7/16 (62)	19 (9)
5-NT	5-tons	8.0 (203)	3.125 (79)	4.4375 (113)	.375 (10)	4.5 (114)	11.75 (298)	5	15/16 (24)	2-7/16 (62)	20 (9)
8-NT	8-tons	8.0 (203)	3.125 (79)	5.3125 (135)	.375 (10)	5.0 (127)	11.75 (298)	5	15/16 (24)	3-5/16 (84)	24 (11)
15-NT	15-tons	10.625 (270)	3.875 (98)	5.1875 (132)	.625 (16)	5.0 (127)	14.75 (375)	5	1-3/16 (30)	2-3/4 (70)	41 (19)
20-NT	20-tons	10.625 (270)	3.875 (98)	6.4375 (164)	.625 (16)	6.5 (165)	14.75 (375)	5	1-3/16 (30)	4 (102)	52 (24)
37.5-NT	37.5-tons	15.0 (381)	5.5 (140)	7.25 (184)	.75 (19)	7.0 (178)	21.0 (533)	6	1-5/8 (41)	3-1/2 (89)	112 (51)
50-NT	50-tons	18.5 (470)	5.5 (140)	7.25 (184)	.75 (19)	7.0 (178)	22.5 (572)	8	1-5/8 (41)	3-1/2 (89)	140 (64)
75-NT	75-tons	21.0 (533)	6.75 (171)	7.375 (187)	1.00 (25)	7.5 (191)	27.0 (686)	7	1-15/16 (49)	3-5/8 (92)	210 (95)

* Height includes Top Plate Thickness

T



Capacity Metric Tons	<<<<<Body Dimensions>>>>>			<<<<<Top Plate Dimensions>>>>>			<<<<<Footprint>>>>>				
	Length	Height	Width	Thickness	Width	Length	Contact Rolls	Roll Dia. <<<<<Inches (mm)>>>>>	Roll Width <<<<<Inches (mm)>>>>>	Weight Lbs.(kgs)	
.75-T	.75-ton	6.5 (165)	3.125 (79)	3.625 (92)	.375 (10)	3.5 (89)	6.5 (165)	6	11/16 (17)	2 (51)	11 (5)
1-T	1-ton	6.0 (152)	2.375 (60)	3.5625 (91)	.375 (10)	3.5 (89)	6.0 (152)	6	11/16 (17)	2 (51)	9 (4)
2.5-T	2.5-tons	6.5 (165)	3.625 (92)	4.125 (105)	.375 (10)	4.0 (102)	6.5 (165)	4	15/16 (24)	2-7/16 (62)	17 (8)
5-T	5-tons	8.0 (203)	3.125 (79)	4.4375 (113)	.375 (10)	4.5 (114)	8.0 (203)	5	15/16 (24)	2-7/16 (62)	19 (9)
8-T	8-tons	8.0 (203)	3.125 (79)	5.3125 (135)	.375 (10)	5.0 (127)	8.0 (203)	5	15/16 (24)	3-5/16 (84)	22 (10)
15-T	15-tons	10.625 (270)	3.875 (98)	5.1875 (132)	.625 (16)	5.0 (127)	10.625 (270)	5	1-3/16 (30)	2-3/4 (70)	38 (17)
20-T	20-tons	10.625 (270)	3.875 (98)	6.4375 (164)	.625 (16)	6.5 (165)	10.625 (270)	5	1-3/16 (30)	4 (102)	47 (21)
37.5-T	37.5-tons	15.0 (381)	5.5 (140)	7.25 (184)	.75 (19)	7.0 (178)	15.0 (381)	6	1-5/8 (41)	3-1/2 (89)	103 (47)
50-T	50-tons	18.5 (470)	5.5 (140)	7.25 (184)	.75 (19)	7.0 (178)	18.5 (470)	8	1-5/8 (41)	3-1/2 (89)	134 (61)
75-T	75-tons	21.0 (533)	6.75 (171)	7.375 (187)	1.00 (25)	7.5 (191)	21.0 (533)	7	1-15/16 (49)	3-5/8 (92)	198 (90)

* Height includes Top Plate Thickness

The ERF Series has no top plate which means the roller is lower in overall height and lighter in weight. These are ideal if a user intends to weld-mount the rollers. The tops of the side plates can be machined to close tolerance.

ERF



Capacity Metric Tons	<<<<<Body Dimensions>>>>>			<<<<<Footprint>>>>>			Weight Lbs.(kgs)
	Length	Height	Width	Contact Rolls	Roll Dia. <<<<<Inches (mm)>>>>>	Roll Width <<<<<Inches (mm)>>>>>	
1-ERF	1-Ton	6.00 (152)	2.00 (51)	3.58 (91)	5	11/16 (17)	7 (3)
4-ERF	4-Tons	8.00 (203)	2.75 (70)	4.44 (113)	5	15/16 (24)	14 (6)
12-ERF	12-Tons	10.625 (270)	3.25 (83)	5.625 (143)	5	1-3/16 (30)	30 (14)
30-ERF	30-Tons	15.00 (381)	4.75 (121)	7.00 (178)	5	1-5/8 (41)	82 (37)
65-ERF	65-Tons	21.00 (533)	5.75 (146)	7.375 (187)	7	1-15/16 (49)	165 (75)
100-ERF	100-Tons	21.00 (533)	5.75 (146)	7.875 (200)	7	1-15/16 (49)	180 (82)
125-ERF	125-Tons	21.00 (533)	5.75 (146)	9.875 (251)	14	1-15/16 (49)	229 (104)

The Super Heavy Duty Rollers are the highest capacity rollers that Hilman offers as standard models. 150 & 200 Ton frames come in Long (L) or Wide (W). Wide frame versions are offered with one complete (wide) chain or with two individual chains with a center plate (C) dividing them.

XOT • XOTL • XOTW • XOTWC



	Capacity Metric Tons	<<<<<<Body Dimensions>>>>>>>>			<<<<<<Top Plate Dimensions>>>>>>>>			Contact Rolls	<<<<<<Footprint>>>>>>>>		Weight Lbs.(kgs)
		Length	Height	Width	Thickness	Width	Length		Roll Dia.	Roll Width	
		<<<<<<<Inches (mm)>>>>>>>>			<<<<<<<Inches (mm)>>>>>>>>				<<<<<<<Inches (mm)>>>>>>>>		
100-XOT	100-tons	21.0 (533)	6.75 (171)	7.875 (200)	1.00 (25)	14.0 (356)	21.0 (533)	7	1-15/16 (49)	3-5/8 (92)	250 (113)
150-XOTL	150-tons	32.0 (813)	6.75 (171)	7.875 (200)	1.00 (25)	14.0 (356)	32.0 (813)	11	1-15/16 (49)	3-5/8 (92)	381 (172)
150-XOTW	150-tons	21.0 (533)	6.75 (171)	9.875 (251)	1.00 (25)	16.0 (406)	21.0 (533)	14	1-15/16 (49)	2-3/4 (70)	299 (136)
200-XOTL	200-tons	36.0 (914)	6.75 (171)	7.875 (200)	1.00 (25)	14.0 (356)	36.0 (914)	14	1-15/16 (49)	3-5/8 (92)	443 (201)
200-XOTW	200-tons	21.0 (533)	6.75 (171)	11.5625 (294)	1.00 (25)	21.0 (533)	21.0 (533)	14	1-15/16 (49)	3-5/8 (92)	364 (165)
200-XOTWC	200-tons	21.0 (533)	6.75 (171)	14.5 (368)	1.00 (25)	21.0 (533)	21.0 (533)	14	1-15/16 (49)	3-5/8 (92)	423 (192)
300-XOT	300-tons	34.0 (864)	10.0 (254)	10.75 (273)	1.50 (38)	21.0 (533)	34.0 (864)	8	2-15/16 (74)	5 (127)	849 (385)
500-XOT	500-tons	34.0 (864)	10.0 (254)	20.0 (508)	1.50 (38)	30.0 (762)	34.0 (864)	16	2-15/16 (74)	5 (127)	1430 (649)
750-XOT	750-tons	34.0 (864)	10.0 (254)	27.5 (699)	1.50 (38)	37.5 (953)	34.0 (864)	24	2-15/16 (74)	5 (127)	2044 (927)
1000-XOT	1000-tons	*****CONSULT FACTORY FOR SPECIFICATIONS AND WEIGHT*****									

XNT • XNTL • XNTW • XNTWC



	Capacity Metric Tons	<<<<<<Body Dimensions>>>>>>>>			<<<<<<Top Plate Dimensions>>>>>>>>			Contact Rolls	<<<<<<Footprint>>>>>>>>		Weight Lbs.(kgs)
		Length	Height	Width	Thickness	Width	Length		Roll Dia.	Roll Width	
		<<<<<<<Inches (mm)>>>>>>>>			<<<<<<<Inches (mm)>>>>>>>>				<<<<<<<Inches (mm)>>>>>>>>		
100-XNT	100-tons	21.0 (533)	6.75 (171)	7.875 (200)	1.00 (25)	7.875 (200)	27.0 (686)	7	1-15/16 (49)	3-5/8 (92)	228 (103)
150-XNTL	150-tons	32.0 (813)	6.75 (171)	7.875 (200)	1.00 (25)	7.875 (200)	38.0 (965)	11	1-15/16 (49)	3-5/8 (92)	341 (155)
150-XNTW	150-tons	21.0 (533)	6.75 (171)	9.875 (251)	1.00 (25)	9.875 (251)	27.0 (686)	14	1-15/16 (49)	2-3/4 (70)	280 (127)
200-XNTL	200-tons	36.0 (914)	6.75 (171)	7.875 (200)	1.00 (25)	7.875 (200)	42.0 (1067)	14	1-15/16 (49)	3-5/8 (92)	396 (180)
200-XNTW	200-tons	21.0 (533)	6.75 (171)	11.5625 (294)	1.00 (25)	11.5625 (294)	27.0 (686)	14	1-15/16 (49)	3-5/8 (92)	333 (151)
200-XNTWC	200-tons	21.0 (533)	6.75 (171)	14.5 (368)	1.00 (25)	14.5 (368)	27.0 (686)	14	1-15/16 (49)	3-5/8 (92)	408 (185)
300-XNT	300-tons	34.0 (864)	10.0 (254)	10.75 (273)	1.50 (38)	10.75 (273)	42.0 (1067)	8	2-15/16 (74)	5 (127)	739(335)
500-XNT	500-tons	34.0 (864)	10.0 (254)	20.0 (508)	1.50 (38)	20.0 (508)	42.0 (1067)	16	2-15/16 (74)	5 (127)	1355 (615)
750-XNT	750-tons	34.0 (864)	10.0 (254)	27.5 (699)	1.50 (38)	27.5 (699)	42.0 (1067)	24	2-15/16 (74)	5 (127)	2009 (911)
1000-XNT	1000-tons	*****CONSULT FACTORY FOR SPECIFICATIONS AND WEIGHT*****									

XT • XTL • XTW • XTWC



	Capacity Metric Tons	<<<<<<Body Dimensions>>>>>>>>			<<<<<<Top Plate Dimensions>>>>>>>>			Contact Rolls	<<<<<<Footprint>>>>>>>>		Weight Lbs.(kgs)
		Length	Height	Width	Thickness	Width	Length		Roll Dia.	Roll Width	
		<<<<<<<Inches (mm)>>>>>>>>			<<<<<<<Inches (mm)>>>>>>>>				<<<<<<<Inches (mm)>>>>>>>>		
100-XT	100-tons	21.0 (533)	6.75 (171)	7.875 (200)	1.00 (25)	7.875 (200)	21.0 (533)	7	1-15/16 (49)	3-5/8 (92)	217 (98)
150-XTL	150-tons	32.0 (813)	6.75 (171)	7.875 (200)	1.00 (25)	7.875 (200)	32.0 (813)	11	1-15/16 (49)	3-5/8 (92)	329 (149)
150-XTW	150-tons	21.0 (533)	6.75 (171)	9.875 (251)	1.00 (25)	9.875 (251)	21.0 (533)	14	1-15/16 (49)	2-3/4 (70)	265 (120)
200-XTL	200-tons	36.0 (914)	6.75 (171)	7.875 (200)	1.00 (25)	7.875 (200)	36.0 (914)	14	1-15/16 (49)	3-5/8 (92)	384 (174)
200-XTW	200-tons	21.0 (533)	6.75 (171)	11.5625 (294)	1.00 (25)	11.5625 (294)	21.0 (533)	14	1-15/16 (49)	3-5/8 (92)	313 (142)
200-XTWC	200-tons	21.0 (533)	6.75 (171)	14.5 (368)	1.00 (25)	14.5 (368)	21.0 (533)	14	1-15/16 (49)	3-5/8 (92)	387 (175)
300-XT	300-tons	34.0 (864)	10.0 (254)	10.75 (273)	1.50 (38)	10.75 (273)	34.0 (864)	8	2-15/16 (74)	5 (127)	706 (320)
500-XT	500-tons	34.0 (864)	10.0 (254)	20.0 (508)	1.50 (38)	20.0 (508)	34.0 (864)	16	2-15/16 (74)	5 (127)	1290 (585)
750-XT	750-tons	34.0 (864)	10.0 (254)	27.5 (699)	1.50 (38)	27.5 (699)	34.0 (864)	24	2-15/16 (74)	5 (127)	1892 (858)
1000-XT	1000-tons	*****CONSULT FACTORY FOR SPECIFICATIONS AND WEIGHT*****									

OTB, NTB, TB

You can purchase a standard OTB/NTB/TB Series roller for which a separate, bolt-on style Accu-Roll Guidance System may be added at some point in the future. Note that these models do not come standard with any guidance system. These models can be particularly handy for users who frequently need to change the type of track that the rollers will ride upon. The NTB models have longer top plates than their NT counterparts to prevent interference when mounting the load to the top plate.

These Accu-Roll System B, bolt onto a backing block attached to a Hilman Roller (OTB, NTB, AND TB Series). This gives users the flexibility to adapt to more than one track or channel, or to remove the Accu-Roll entirely. There are adjustable version, quick-release versions and versions that are available in different materials to fit almost every application requirements.

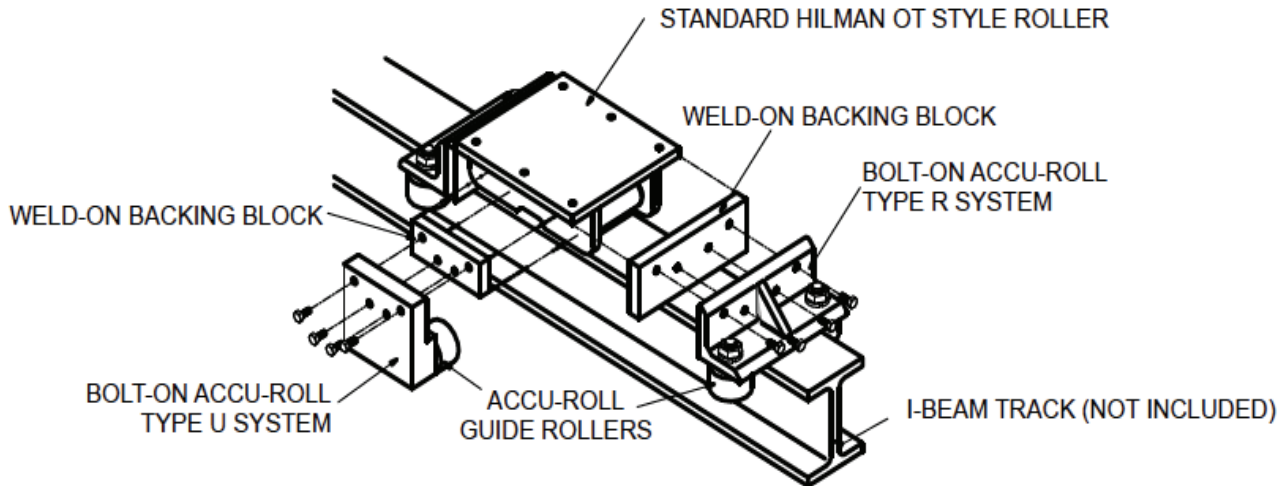

OTB



NTB



TB



	Capacity Metric Tons	Body Dimensions			Top Plate Dimensions			Contact Rolls	Footprint		Weight lbs.(kgs)
		Length	Height*	Width	Thickness	Width	Length		Roll Dia.	Roll Width	
		<<<<Inches (mm)>>>>	<<<<Inches (mm)>>>>	<<<<Inches (mm)>>>>	<<<<Inches (mm)>>>>	<<<<Inches (mm)>>>>	<<<<Inches (mm)>>>>	<<<<Inches (mm)>>>>	<<<<Inches (mm)>>>>	<<<<Inches (mm)>>>>	
5-OTB	5-tons	9.0 (229)	3.125 (79)	4.5625 (116)	.375 (10)	8.0 (203)	8.0 (203)	5	0.9375 (24)	2.4375 (62)	24 (11)
8-OTB	8-tons	9.0 (229)	3.125 (79)	5.3125 (135)	.375 (10)	8.0 (203)	8.0 (203)	5	0.9375 (24)	3.3125 (84)	27 (12)
15-OTB	15-tons	12.125 (308)	3.875 (98)	5.3125 (135)	.625 (16)	10.0 (254)	10.625 (270)	5	1.1875 (30)	2.75 (70)	52 (24)
20-OTB	20-tons	12.125 (308)	3.875 (98)	6.5625 (167)	.625 (16)	10.0 (254)	10.625 (270)	5	1.1875 (30)	4.0 (102)	60 (27)
37.5-OTB	37.5-tons	17.0 (432)	5.5 (140)	7.25 (184)	.75 (19)	12.0 (305)	15.0 (381)	5	1.625 (41)	3.5 (89)	132 (60)
50-OTB	50-tons	20.5 (521)	5.5 (140)	7.25 (184)	.75 (19)	12.0 (305)	18.5 (470)	7	1.625 (41)	3.5 (89)	166 (75)
75-OTB	75-tons	23.0 (584)	6.75 (171)	7.375 (187)	1.00 (25)	14.0 (356)	21.0 (533)	7	1.9375 (49)	3.625 (92)	250 (113)
5-NTB	5-tons	9.0 (229)	3.125 (79)	4.5625 (116)	.375 (10)	4.5 (114)	14.25 (362)	5	0.9375 (24)	2.4375 (62)	24 (11)
8-NTB	8-tons	9.0 (229)	3.125 (79)	5.3125 (135)	.375 (10)	5.0 (127)	14.25 (362)	5	0.9375 (24)	3.3125 (84)	28 (13)
15-NTB	15-tons	12.125 (308)	3.875 (98)	5.3125 (135)	.625 (16)	5.0 (127)	17.25 (438)	5	1.1875 (30)	2.75 (70)	49 (22)
20-NTB	20-tons	12.125 (308)	3.875 (98)	6.5625 (167)	.625 (16)	6.5 (165)	17.25 (438)	5	1.1875 (30)	4.0 (102)	62 (28)
37.5-NTB	37.5-tons	17.0 (432)	5.5 (140)	7.25 (184)	.75 (19)	7.0 (178)	24.5 (622)	5	1.625 (41)	3.5 (89)	131 (59)
50-NTB	50-tons	20.5 (521)	5.5 (140)	7.25 (184)	.75 (19)	7.0 (178)	28.0 (711)	7	1.625 (41)	3.5 (89)	161 (73)
75-NTB	75-tons	23.0 (584)	6.75 (171)	7.375 (187)	1.00 (25)	7.5 (191)	31.5 (800)	7	1.9375 (49)	3.625 (92)	235 (107)
5-TB	5-tons	9.0 (229)	3.125 (79)	4.5625 (116)	.375 (10)	4.5 (114)	8.0 (203)	5	0.9375 (24)	2.4375 (62)	21 (10)
8-TB	8-tons	9.0 (229)	3.125 (79)	5.3125 (135)	.375 (10)	5.0 (127)	8.0 (203)	5	0.9375 (24)	3.3125 (84)	25 (11)
15-TB	15-tons	12.125 (308)	3.875 (98)	5.3125 (135)	.625 (16)	5.0 (127)	10.625 (270)	5	1.1875 (30)	2.75 (70)	43 (20)
20-TB	20-tons	12.125 (308)	3.875 (98)	6.5625 (167)	.625 (16)	6.5 (165)	10.625 (270)	5	1.1875 (30)	4.0 (102)	54 (24)
37.5-TB	37.5-tons	17.0 (432)	5.5 (140)	7.25 (184)	.75 (19)	7.0 (178)	15.0 (381)	5	1.625 (41)	3.5 (89)	117 (53)
50-TB	50-tons	20.5 (521)	5.5 (140)	7.25 (184)	.75 (19)	7.0 (178)	18.5 (470)	7	1.625 (41)	3.5 (89)	147 (67)
75-TB	75-tons	23.0 (584)	6.75 (171)	7.375 (187)	1.00 (25)	7.5 (191)	21.0 (533)	7	1.9375 (49)	3.625 (92)	213 (97)

*Height includes Top Plate Thickness

SHDB Series rollers (XOTB, XOTLB, XOTWB, XOTWC, XNTB, XNTLB, XNTWB, XNTWCB, TB, XTB, XTLB, XTWB, XTWCB) are also available. Please contact us for specifications.

ACCU-ROLL

Hilman's Accu-Roll Guidance System is a positive external alignment system. Most often used on OT/NT/T and SHD Series Hilman Rollers, Accu-Roll can be added to any Hilman Roller and custom designed to interface with almost any type of track. Common tracks are I-beams, Wide-flanged beams, channels, rails, steel flat bars, tubes and trenches. Accu-Roll Systems are an ideal solution where load alignment is critical, a close tolerance must be maintained, where load movement is repetitive or where dynamic uplift prevention is desired.

Because there are virtually thousands of possibilities with regards to tracks, each Accu-Roll System is custom designed and built to fit the chosen track. Once the track size has been selected and the preferred width and depth locations for the Accu-Roll guides known; drawings are prepared for customer approval.

Accu-Roll Systems may have one to four or more guide rolls per roller to guide on the track or to insure that the rollers follow the intended path of travel. Normally designed to withstand a maximum of 20% of the vertical load in side-force; higher or lower capacities can be designed.

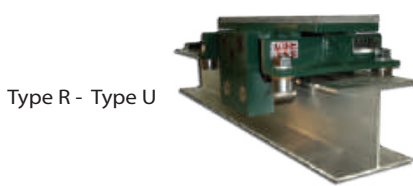

Type R - Type U



Type C

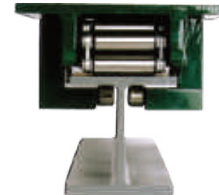

Type U

Track Type	Accu-Roll Type	Application Guidelines
<ul style="list-style-type: none"> • I-Beam • Tube • Bar • Rail 	<p>Type R</p> <p>STRAIGHT ANGLE</p>	<ul style="list-style-type: none"> • Most common system for guidance on OUTSIDE of track • Can consist of one to four Accu-Rolls, mounted to Roller • Ideal for any system, permanent or temporary Flat bar mounted to factory floor provides low height, accessible rolling system with minimal floor surface obstacles
<ul style="list-style-type: none"> • Fabricated Track • Channel 	<p>Type C</p> <p>STRAIGHT ANGLE</p>	<ul style="list-style-type: none"> • Common System for Guidance INSIDE a track or a track imbedded in concrete floor • Can consist of one to four Accu-Rolls; two can be installed on one end or on one side, or in center of Roller frame side • Track can be standard channel, inside flanges of H-Beam, fabricated track from back-to-back angles, etc.
<ul style="list-style-type: none"> • Uplift 	<p>Type RU</p> <p>STRAIGHT ANGLE</p>	<ul style="list-style-type: none"> • Most often added to Type R System • Can consist of one or more Accu-Rolls per side Prevents UPLIFT in dynamic condition • Resistance against wind and buoyancy • Protection against overturning moment • Aids in moving top-heavy or eccentrically loaded equipment

MODIFICATIONS

TOP MODIFICATIONS

Modifications to the top plates of Hilman Rollers can range greatly. Some relatively simple top modifications might be special drilled and tapped hole patterns, connecting studs or tops machined to close tolerances. Top clamps, hinged adaptations or container fittings can be added to the rollers, as well as other types of attachments, for the purpose of mounting to a specific type of footing or pad. Below are several examples.

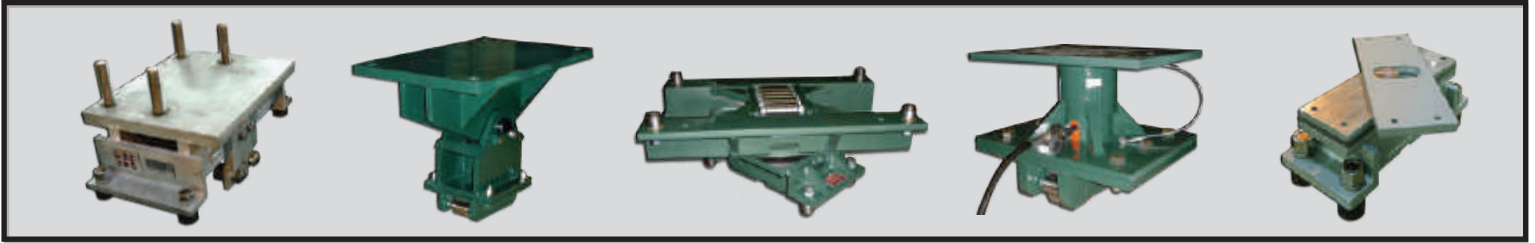

CHAIN MODIFICATIONS

There are several different modifications that Hilman can do to the chains. Tapered roller chains allow Hilman Rollers to follow a fixed radius. Keyway chains are an internal feature to maximize chain life. In highly repetitive applications or where rollers encounter bursts of speed; the Keyway feature keeps the chain centered in the roller frame. Concave and Convex chain and frame solutions are also possible. Hilman can even design specially contoured chain where the rolls are machined to match the contour of crowned rails, ensuring sufficient contact area.



FRAME MODIFICATIONS

Roller frames and tops can be modified in any number of ways to suit specific requirements. Special materials can be used for corrosive resistant or non sparking applications. Mounting surfaces can have custom hole patterns or machined finishes.



TRACK WIPERS OR DIRT SHIELDS

Many wiper and shield styles can be added to Rollers for use in extremely dirty or abusive conditions to minimize the exposure of dirt and dust to the roller chain.



MODIFICATIONS

SPECIAL MATERIALS & COATINGS

Many different alloys and coatings are available for making Hilman rollers meet the requirements of different applications. Alloys to resist varying levels of corrosion, high heat, and non-sparking conditions are just some of what is available for the chain assembly. Special coatings, paint finishes, galvanizing processes or platings can be applied to help in a variety of environments. Hilman typically uses the highest grade alloys and stainless steels available to insure that the rollers operate continuously in the manner intended.

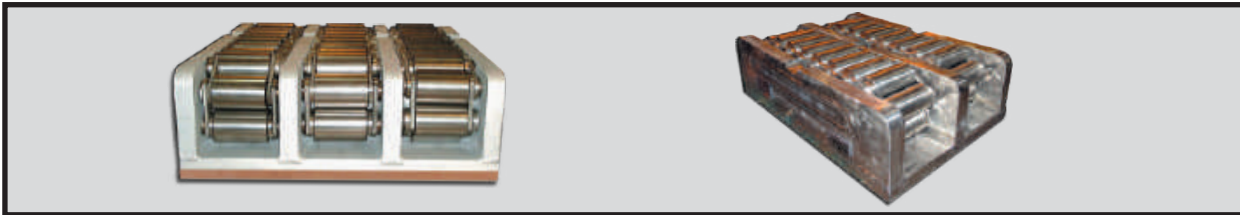

OTHER MODIFICATIONS

Hilman's extensive experience in custom modifications of rollers and rolling systems design covers a broad spectrum of applications. Below are some of our more elaborate modifications.





HILMAN INC.
12 Timber Lane
Marlboro, New Jersey 07746
USA
Phone: +1-732-462-6277
E-mail: sales@hilmanrollers.com
Website: www.hilmanrollers.com

ISO 9001